

## PS-100

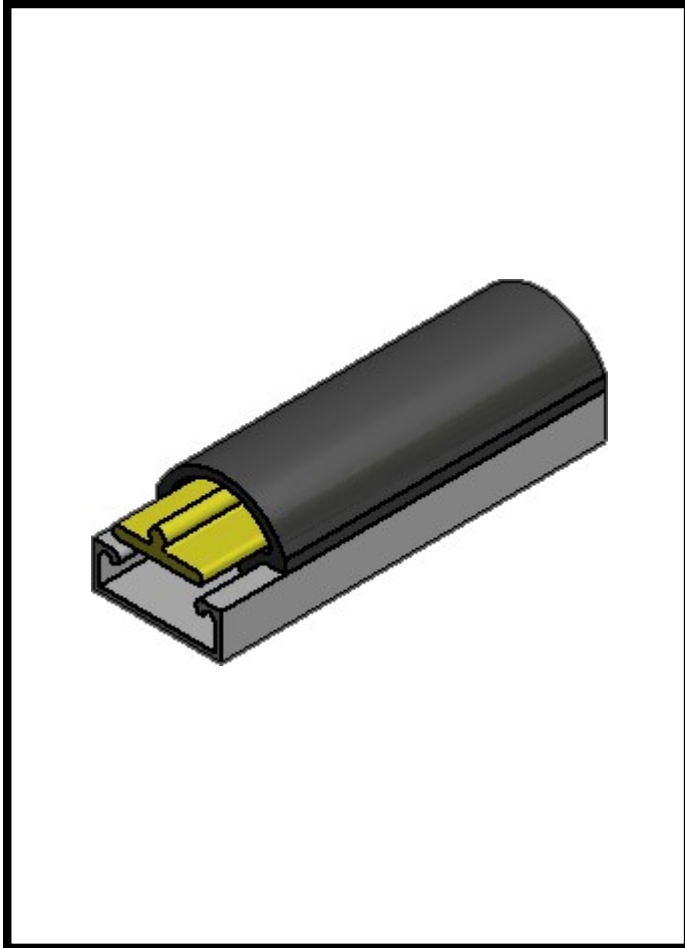

**PS-100** type safety edges are designed in accordance with EN 13856-2.

They are designed to protect personnel against impacts, crushes and/or dismemberment of body parts, when installed on leading edges of a power driven object or automated machine.

In the range of different **Proswitch™** profiles, the **PS-100** type has the smallest profile size, that allows it to be installed in narrow sections, keeping the machine design intact.

Its functioning principle was developed to allow a long duration and a reliable performance.

The switch is sealed inside the edge housing, in order to guarantee a good protection against solid and liquid agents. On demand, the **PS-100** type safety edge can meet the requirements of the IP65 protection class.

Both the edge housing and the edge channel are easily and prompt to install and to substitute, in case of damages or wear.

### General features

Edge housing material:	EPDM
Edge housing colour:	Black
Edge housing hardness:	70 shore
Dimensional tolerances:	DIN ISO 3302-1 E2 class
Edge channel material:	Aluminium
Wires:	PVC insulated copper
Protection level:	IP56 (IP65 on request)
Total weight:	0,4 Kg
Actuations number:	2x10 <sup>6</sup>
Switch contact type:	N.O.
Inactive zone on each end of the edge:	15 mm
Actuation angle:	30°
Max. length:	65 m (one piece or serial pieces)
Functioning temperature:	-10°C + 65°C @ 10 mm/s or 0°C + 65°C @ 100 mm/s

## Dimensions

### Safety edge dimensions

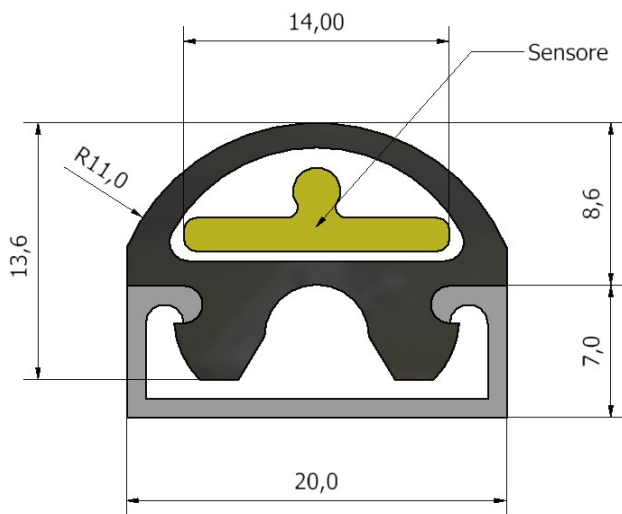

### Edge housing GM-H10 + switch



### Aluminium edge channel



## Electric features

Resistance:	0,5 Ohm/m
Max current:	1 A
Max tension:	32 Vcc
Max wire length:	100 m (section 0,50 mm <sup>2</sup> copper)

## Mechanical features

Pre-travel:	1.5 mm
Working travel 250 N:	3.4 mm
Working travel 400 N:	4.1 mm
Working travel 600 N:	4.8 mm
Overtravel 250 N:	1.9 mm
Overtravel 400 N:	2.6 mm
Overtravel 600 N:	3.3 mm
Actuating force test rod $\varnothing$ 20 mm:	16 N @ 20°C
Actuating force test rod $\varnothing$ 80 mm:	56 N @ 20°C
Mechanical force:	500 N

## Chemical compatibility

The edge housing profiles are made of **EPDM**, that is compatible with incombustible hydraulic fluids, such as ketones, cold and hot water, alkalis and alcohols, while it is less compatible with oils, aromatic and aliphatic hydrocarbons, halogenated solvents and concentrated acids. In order to assess precisely the edge housing profile with specific substances contact, it is highly recommended to check the analytic tables on the chemical substances, considering the exposure time and the temperature.

## Characteristic curve

Each **Proswitch™** safety edge is designed to meet the requirements of EN 13869-2, and is duly tested through application of force. Such force parameters can be represented on a characteristic graph.

The graph relating safety edge type **PS-100** is the following:

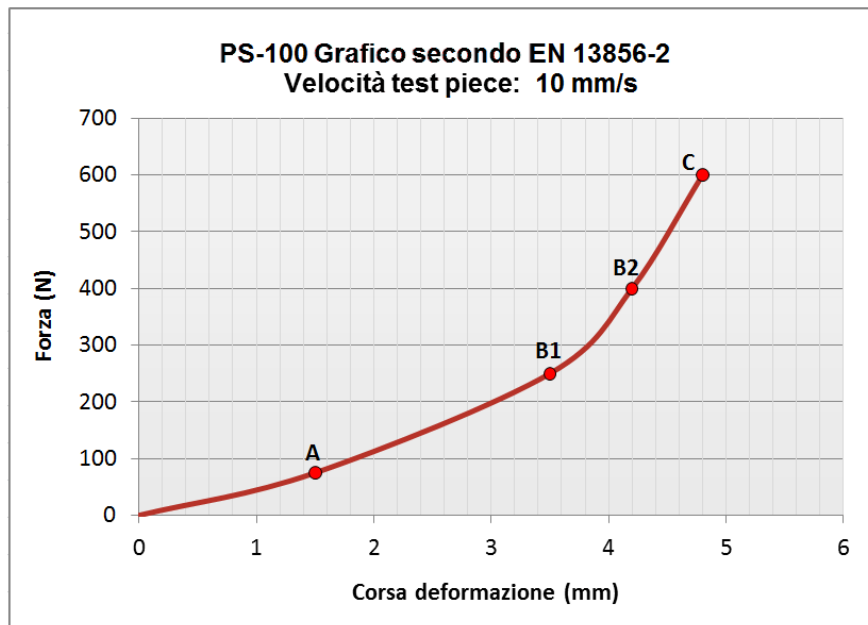

Legend:

- A** Switch activation point
- B1** Travel at 250N
- B2** Travel at 400N
- C** Travel at 600N

## Functioning principle

**Proswitch™** safety edge type **PS-100** is designed to meet the requirements of EN 13856-2. In order to meet the standard CAT 3-PLe ISO 13849-1, **Proswitch™** safety edge type **PS-100** must be used with the **SP-xx** control unit.

The time between the safety edge actuation (**ts**) and the moment the inner sensor's contact gets closed (**te**) is called "edge reaction time" (**Tr**). Such reaction time depends on the "pre-travel" parameter proper of the **Proswitch™** safety edge type **PS-100** and on the force application speed on the safety edge.

$$Tr = \text{pre-travel} / \text{force application speed}$$

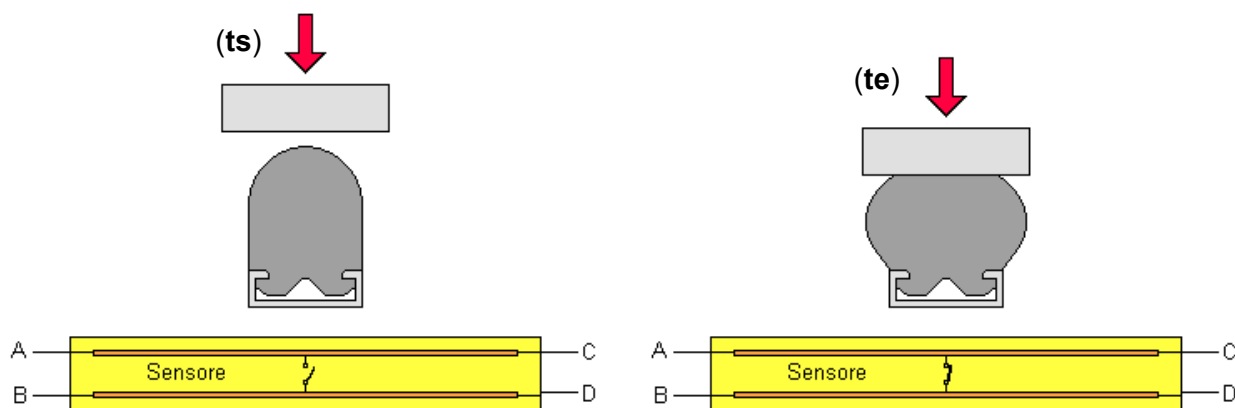

## Dynamic functioning of the safety edge

### Pre-travel

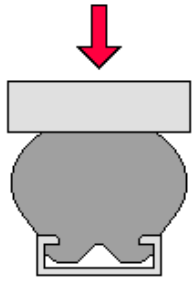

Pre-travel is the distance the test piece travels from the external part of the safety edge to the inner switch actuation, as a consequence of the safety edge cushioning.

In the graph representing the safety edge type **PS-100** characteristic curve (pag. 4), pre-travel is the distance travelled from 0 to point A.

### Overtravel

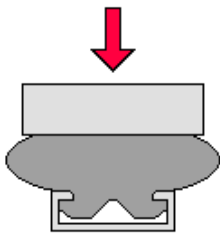

Overtravel is the further cushioning distance of the safety edge, detected at 250 N, 400 N and 600 N. During this phase, the inner switch contact is always closed, and the machine has already started the emergency stop.

In the graph representing the safety edge type **PS-100** characteristic curve (pag. 4), overtravel is the distance travelled from point A to point B1 (250 N), B2 (400 N) and C (600 N).

### Inactive parts

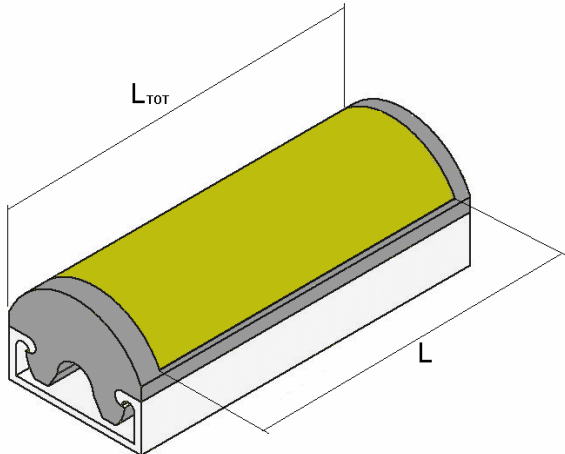

**LTOT**: total edge length

**L**: effective safety length.

The image on the left shows a grey surface, that represents the inactive parts of the safety edge that, if submitted to crushing force, do not compress the inner switch.

The inactive parts are 15 mm long for each edge's end.

The following formula can be used to obtain the value of the effective safety length:

$$L = LTOT - 2 (15 \text{ mm})$$

### View of the safety edge

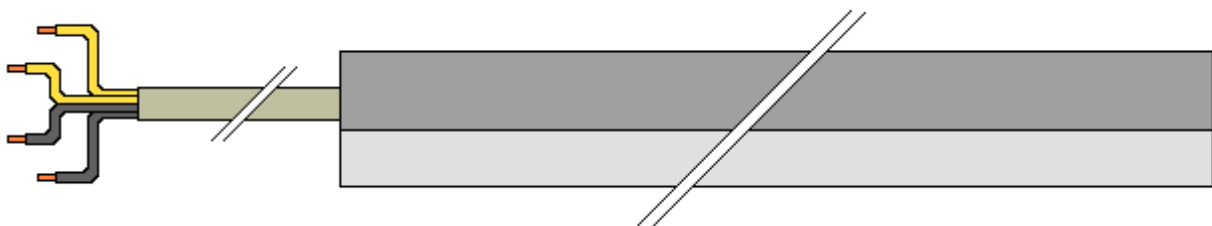

## PS-100 safety edge different types

PS-100 type safety edges may be in three different versions, depending on the wire exit, and in another version that is not used for safety purposes.

### PS-100 safety edge, exit 1 wire 2 poles with final resistance

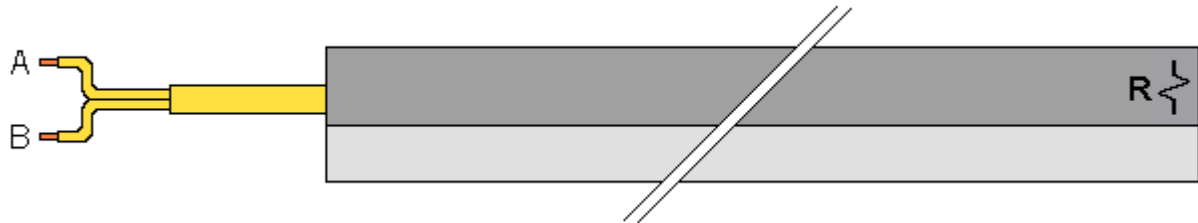

### PS-100 safety edge, exit 1 wire 4 poles

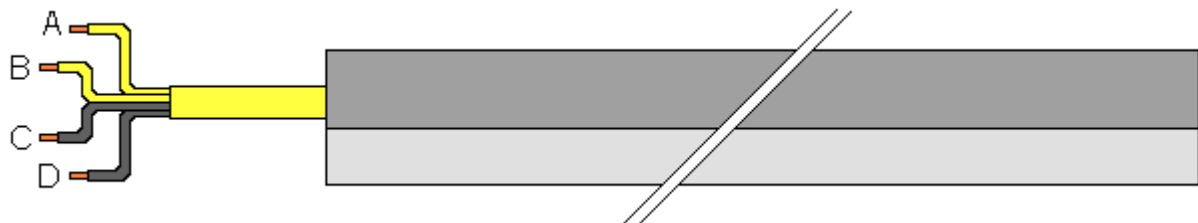

### PS-100 safety edge, exit 2 wires 2 poles

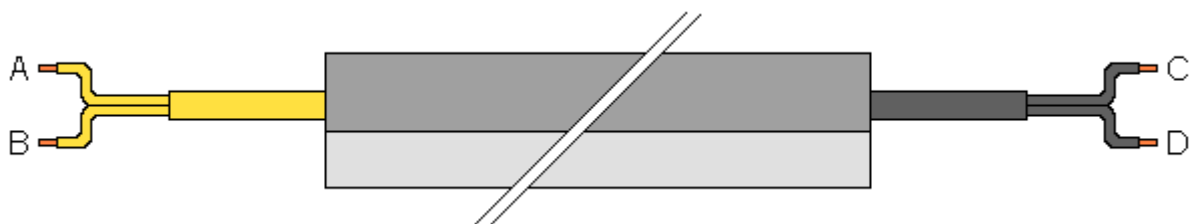

### PS-100 safety edge, exit 1 wire 2 poles, not for safety purposes

